

PRO-FORM[®]

675 CardioCrossTrainer Heart Rate Monitor

Model No. PFEL29240

Serial No. _____

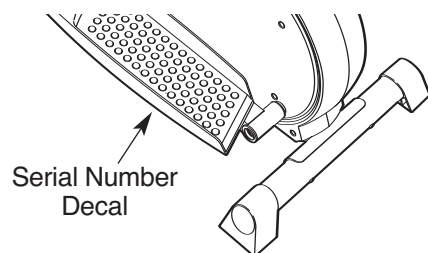

QUESTIONS?

If you have questions, or if there are missing parts, we will guarantee complete satisfaction through direct assistance from our factory.

TO AVOID DELAYS, PLEASE CALL DIRECT TO OUR TOLL-FREE CUSTOMER HOT LINE. The trained technicians on our customer hot line will provide immediate assistance, free of charge to you.

CUSTOMER HOT LINE:

1-888-533-1333

Mon.-Fri., 6 a.m.-6 p.m. MST

! CAUTION

Read all precautions and instructions in this manual before using this equipment. Keep this manual for future reference.

USER'S MANUAL

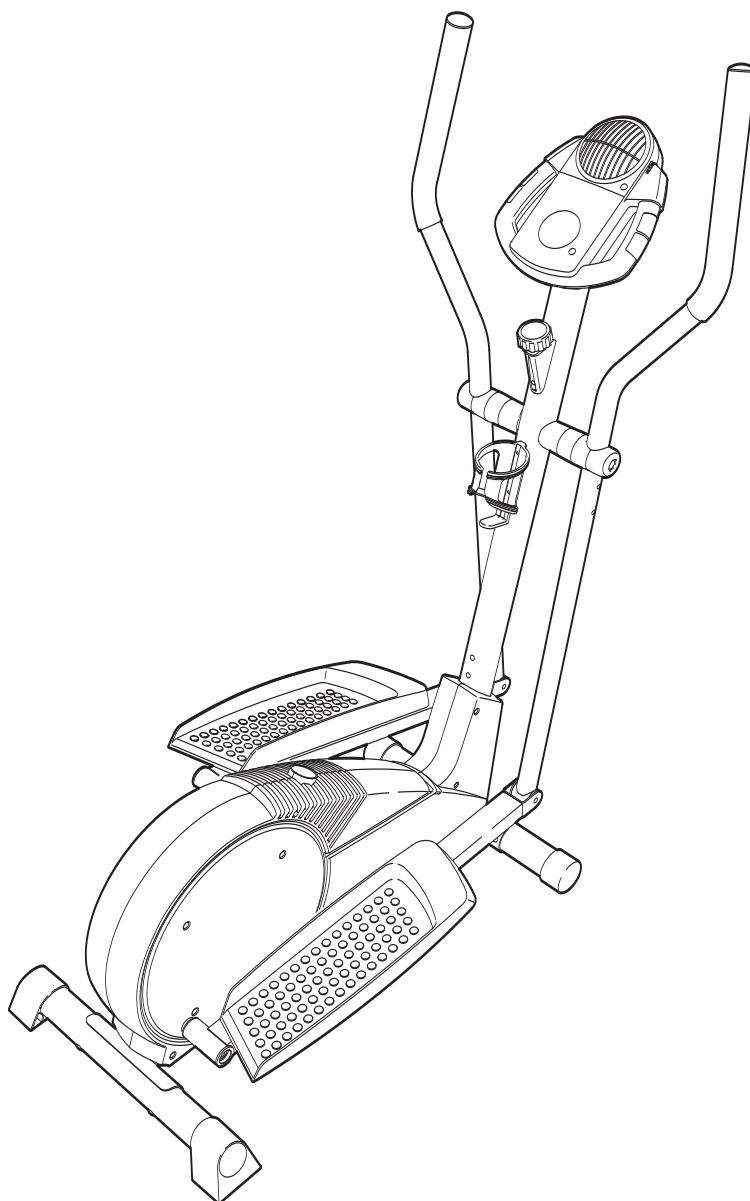

Visit our website at

www.proform.com

new products, prizes,
fitness tips, and much more!

PRO-FORM[®]

675 CardioCrossTrainer Heart Rate Monitor

TABLE OF CONTENTS

IMPORTANT PRECAUTIONS	3
BEFORE YOU BEGIN	4
ASSEMBLY	5
HOW TO USE THE ELLIPTICAL CROSSTRAINER	9
MAINTENANCE AND TROUBLESHOOTING	12
CONDITIONING GUIDELINES	13
PART LIST	14
EXPLODED DRAWING	15
HOW TO ORDER REPLACEMENT PARTSBack Cover
LIMITED WARRANTYBack Cover

IMPORTANT PRECAUTIONS

⚠ WARNING: To reduce the risk of serious injury, read the following important precautions before using the elliptical crosstrainer.

1. Read all instructions in this manual before using the elliptical crosstrainer.
2. It is the responsibility of the owner to ensure that all users of the elliptical crosstrainer are adequately informed of all precautions.
3. Place the elliptical crosstrainer on a level surface, with a mat beneath it to protect the floor or carpet. Keep the elliptical crosstrainer indoors, away from moisture and dust.
4. Inspect and properly tighten all parts regularly. Replace any worn parts immediately.
5. Keep children under 12 and pets away from the elliptical crosstrainer at all times.
6. The elliptical crosstrainer should not be used by persons weighing more than 250 pounds.
7. Wear appropriate exercise clothes when using the elliptical crosstrainer. Always wear athletic shoes for foot protection.
8. Always hold the handles on the console or the handlebars when mounting, dismounting, or using the elliptical crosstrainer.
9. The pulse sensor is not a medical device. Various factors, including the user's movement, may affect the accuracy of heart rate readings. The pulse sensor is intended only as an exercise aid in determining heart rate trends in general.
10. Keep your back straight when using the elliptical crosstrainer; do not arch your back.
11. If you feel pain or dizziness while exercising, stop immediately and cool down.
12. When you stop exercising, allow the pedals to slowly come to a stop.
13. The elliptical crosstrainer is intended for home use only. Do not use the elliptical crosstrainer in a commercial, rental, or institutional setting.
14. The warning decal shown on page 4 has been applied to the elliptical crosstrainer. If the decal is missing, or if it is not legible, call our Customer Service Department toll-free at 1-888-533-1333 and order a free replacement decal. Apply the decal in the location shown.

⚠ WARNING: Before beginning this or any exercise program, consult your physician. This is especially important for persons over the age of 35 or persons with pre-existing health problems. Read all instructions before using. ICON assumes no responsibility for personal injury or property damage sustained by or through the use of this product.

BEFORE YOU BEGIN

Congratulations for selecting the new PROFORM® 675 CARDIO CROSSTRAINER. The PROFORM 675 is an incredibly smooth exerciser that moves your feet in a natural elliptical path, minimizing the impact on your knees and ankles. And the unique PROFORM 675 features adjustable resistance and a simple-to-use console to help you get the most from your exercise. Welcome to a whole new world of natural, elliptical-motion exercise from PROFORM.



For your benefit, read this manual carefully before using the elliptical crosstrainer. If you have ques-

tions after reading this manual, please call our Customer Service Department toll-free at 1-888-533-1333, Monday through Friday, 6 a.m. until 6 p.m. Mountain Time (excluding holidays). To help us assist you, please note the product model number and serial number before calling. The model number is PFEL29240. The serial number is found on a decal attached to the elliptical crosstrainer (see the front cover of this manual for the location of the decal).

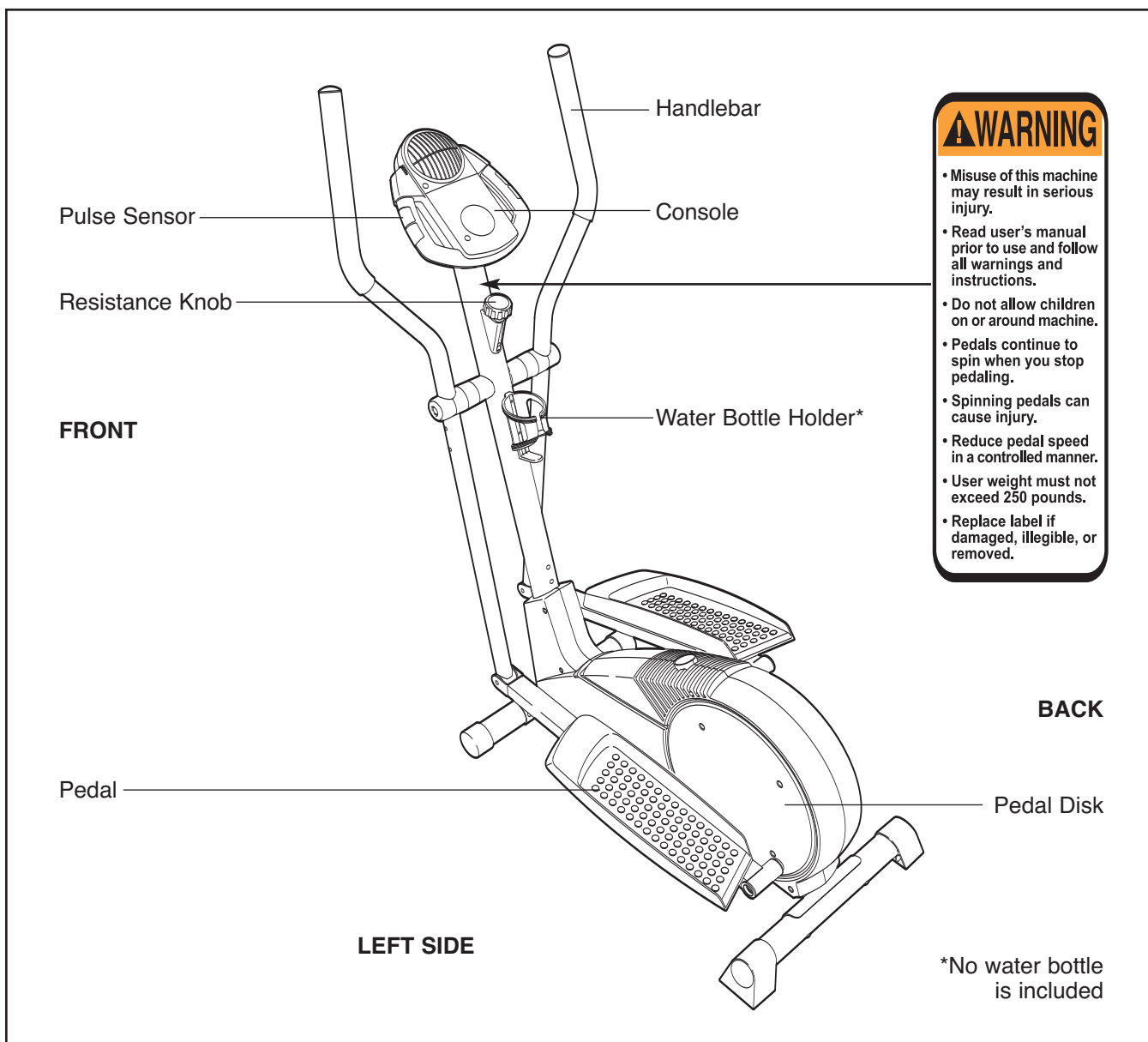
Before reading further, please familiarize yourself with the parts that are labeled in the drawing below.



ASSEMBLY

Assembly requires two persons. Place all parts of the elliptical crosstrainer in a cleared area and remove the packing materials. Do not dispose of the packing materials until assembly is completed. **In addition to the included allen wrenches, assembly requires a phillips screwdriver** , **an adjustable wrench** , **and a rubber mallet** .

As you assemble the elliptical crosstrainer, use the drawings below to identify the small parts used in assembly. The number in parenthesis below each drawing refers to the key number of the part, from the PART LIST on page 14. The second number refers to the quantity used in assembly. **Note: Some small parts may have been pre-assembled for shipping. If a part is not in the parts bag, check to see if it has been pre-assembled.**

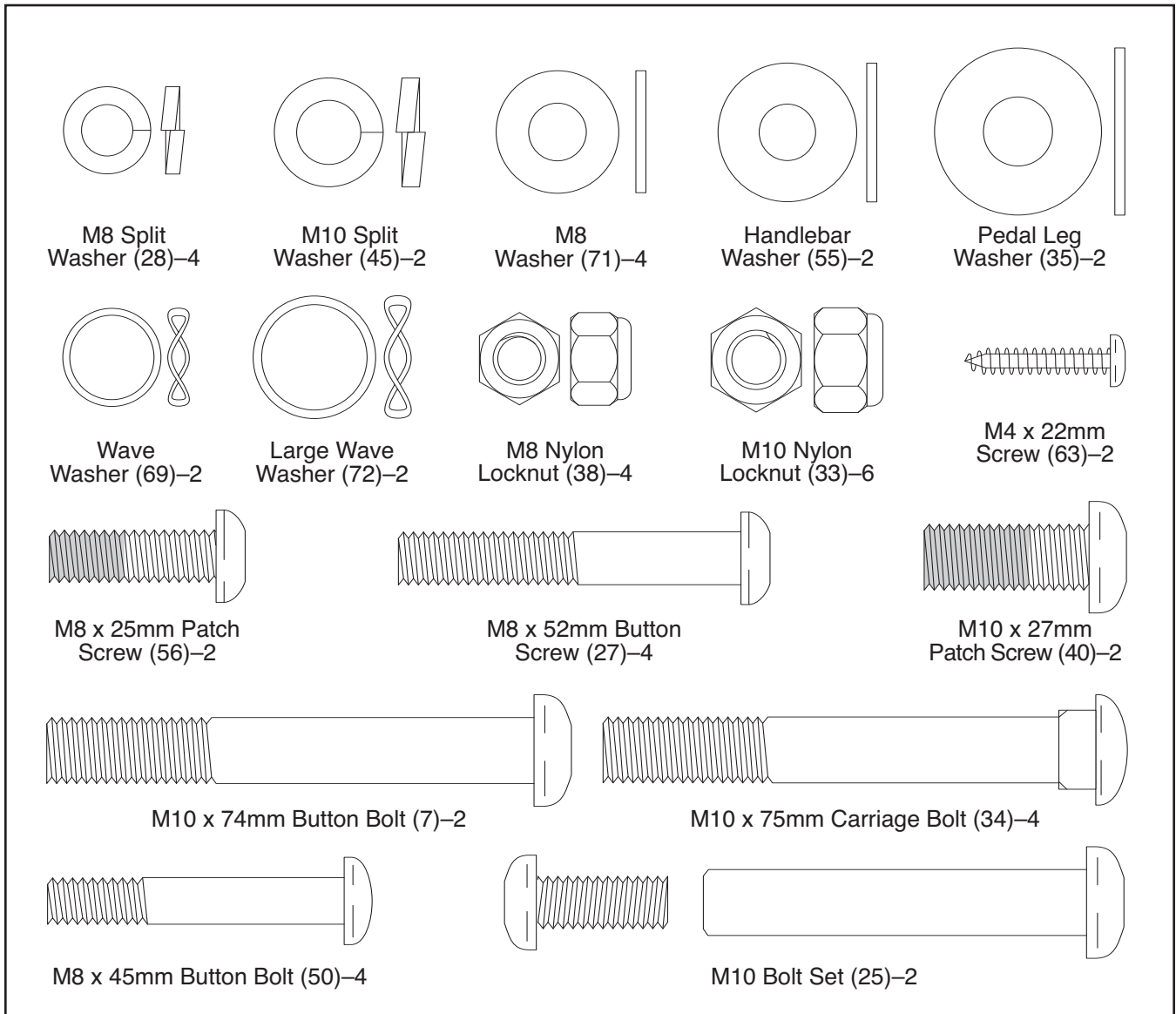

1. Identify the Front Stabilizer (10), which has round Endcaps (21) on its ends. While another person lifts the front of the Frame (1), attach the Front Stabilizer to the Frame with two M10 x 75mm Carriage Bolts (34) and two M10 Nylon Locknuts (33).

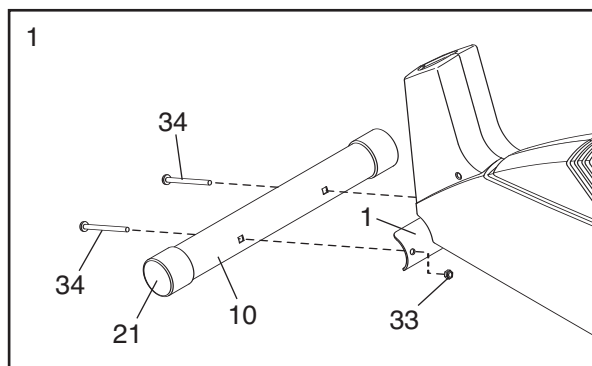

2. While another person lifts the back of the Frame (1), attach the Rear Stabilizer (9) to the Frame with two M10 x 75mm Carriage Bolts (34) and two M10 Nylon Locknuts (33).

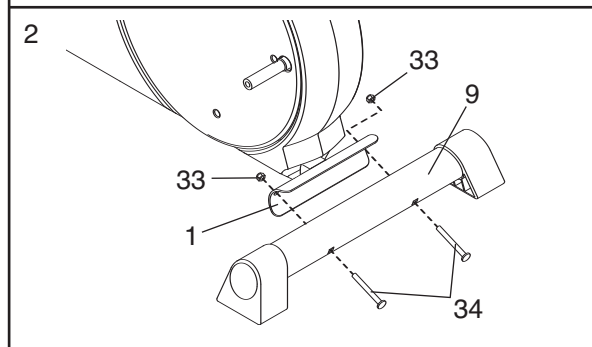

3. The Console (23) requires four 1.5V "D" batteries; alkaline batteries are recommended. Remove the indicated screw from the battery drawer, and pull the battery drawer open. Insert four batteries into the battery drawer; **make sure that the batteries are oriented as shown by the markings inside of the battery drawer**. Close the battery drawer and reattach the screw. Note: When the batteries are installed correctly, the fan will turn on for a moment.

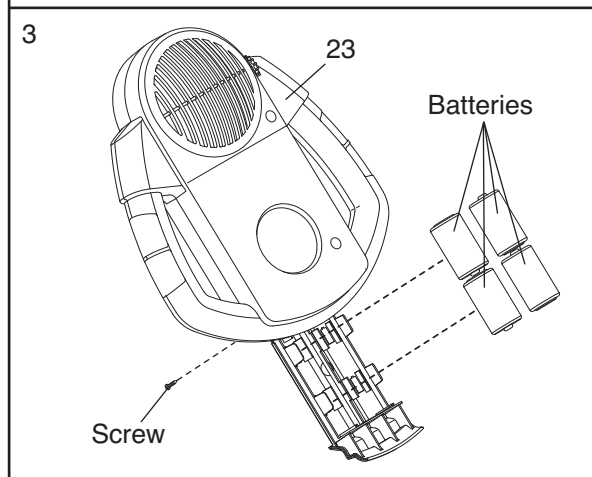

4. While another person holds the Console (23) in the position shown, connect the console wire to the Extension Wire (68).

Attach the Console (23) to the Upright (2) with the four Console Screws (59) included with the Console. **Be careful to avoid pinching the wires.**

Attach the Water Bottle Holder (29) to the Upright (2) with two M4 x 22mm Screws (63).

Turn the Resistance Control (42) counterclockwise to the lowest setting before continuing.

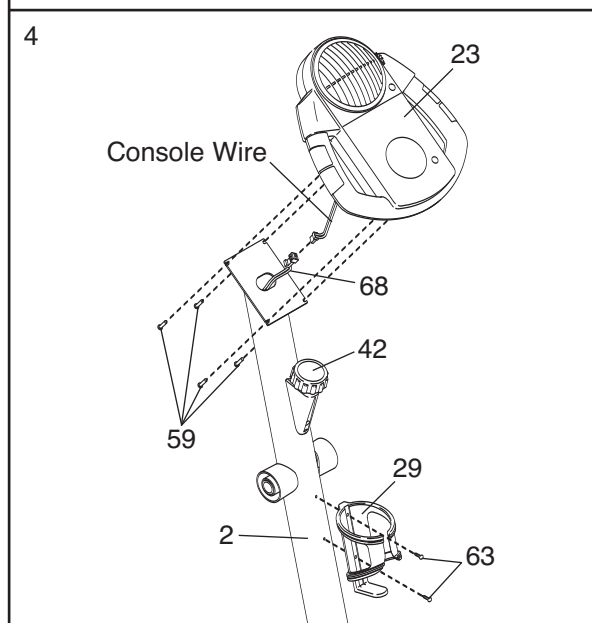

5. While another person holds the Upright (2) in the position shown, connect the Extension Wire (68) to the Reed Switch Wire (53). Next, connect the Resistance Cable (42) to the Lower Resistance Cable (43) in the following way:

- See drawing A. Pull up on the metal bracket, and insert the tip of the Resistance Cable (42) into the wire clip on the Lower Resistance Cable (43) as shown.
- See drawing B. **Firmly** pull the Resistance Cable (42) and slide it into the metal bracket on the Lower Resistance Cable (43) as shown.
- See drawing C. Using pliers, squeeze the prongs on the upper end of the metal bracket together.

Push the excess cable and wires down into the Frame (1). Slide the Upright (2) onto the Frame. **Do not pinch the wires or cables.** Attach the Upright to the Frame with two M10 x 74mm Button Bolts (7), two M10 Split Washers (45), and two M10 Nylon Locknuts (33). **Do not tighten the Bolts yet.**

6. Identify the Left Handlebar (6), which is marked with a sticker. Insert the Left Handlebar into one of the Handlebar Legs (5); **make sure that the Handlebar Leg is turned so the hexagonal holes are on the indicated side.** Attach the Left Handlebar to the Handlebar Leg with two M8 x 45mm Button Bolts (50) and two M8 Nylon Locknuts (38). **Make sure that the Nylon Locknuts are inside of the hexagonal holes.** **Do not fully tighten the Button Bolts yet.**

Insert the Pivot Axle (26) into the Upright (2), and center the Pivot Axle. Apply a generous amount of the included grease to both ends of the Pivot Axle.

Turn a Handlebar Spacer (47) so that the small arrow on the Handlebar Spacer is pointing toward the floor, and slide the Handlebar Spacer onto the post on the Left Handlebar (6). Next, slide the Left Handlebar onto the Pivot Axle (26).

Slide a Handlebar Washer (55) and a Wave Washer (69) onto an M8 x 25mm Patch Screw (56), and tighten the Patch Screw into the Pivot Axle (26). Then, press the tabs on a Handlebar Cap (46) into the Handlebar Spacer (47).

Assemble the Right Handlebar (8) and the other Handlebar Leg (5) in the same way.

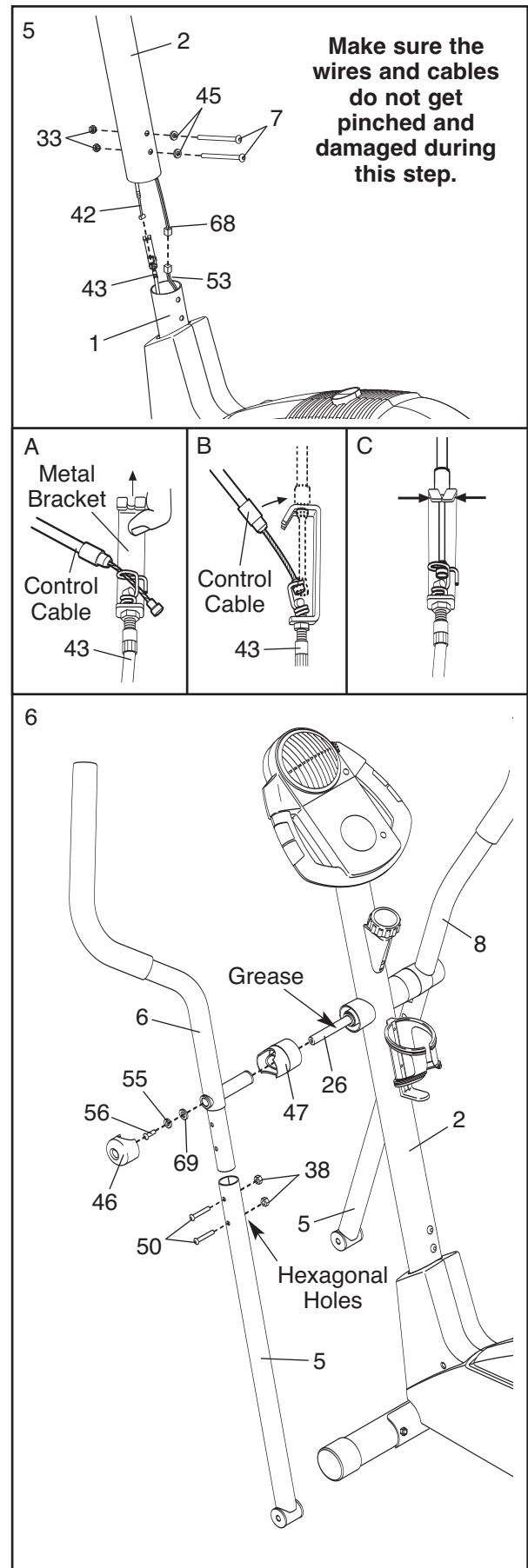

7. Identify the Left Pedal Leg (11), which is marked with a sticker. Attach the Left Pedal (13) to the Left Pedal Leg with two M8 x 52mm Button Screws (27), two M8 Split Washers (28), and two M8 Washers (71).

Attach the Right Pedal (not shown) in the same way.

8. Apply a small amount of grease to the axle on the left Disc Crossbar (16). Slide the Left Pedal Leg (11) onto the axle. Apply a small amount of grease to a Large Wave Washer (72) and press it onto the end of the Left Pedal Leg. Slide a Pedal Leg Washer (35) onto an M10 x 27mm Patch Screw (40), and tighten the Patch Screw into the axle.

Next, hold the lower end of the left Handlebar Leg (5) inside of the bracket on the front of the Left Pedal Leg (11). Apply grease to an M10 Bolt Set (25). Attach the Handlebar Leg to the Left Pedal Leg with the Bolt Set. **Do not overtighten the Bolt Set; the Handlebar Leg must pivot freely.**

Attach the Right Pedal Leg (not shown) to the right side of the elliptical crosstrainer in the same way.

See step 5. Tighten the M10 x 74mm Button Bolts (7) in the Upright (2).

See step 6. Tighten the M8 x 45mm Button Bolts (50) in the Handlebar Legs (5).

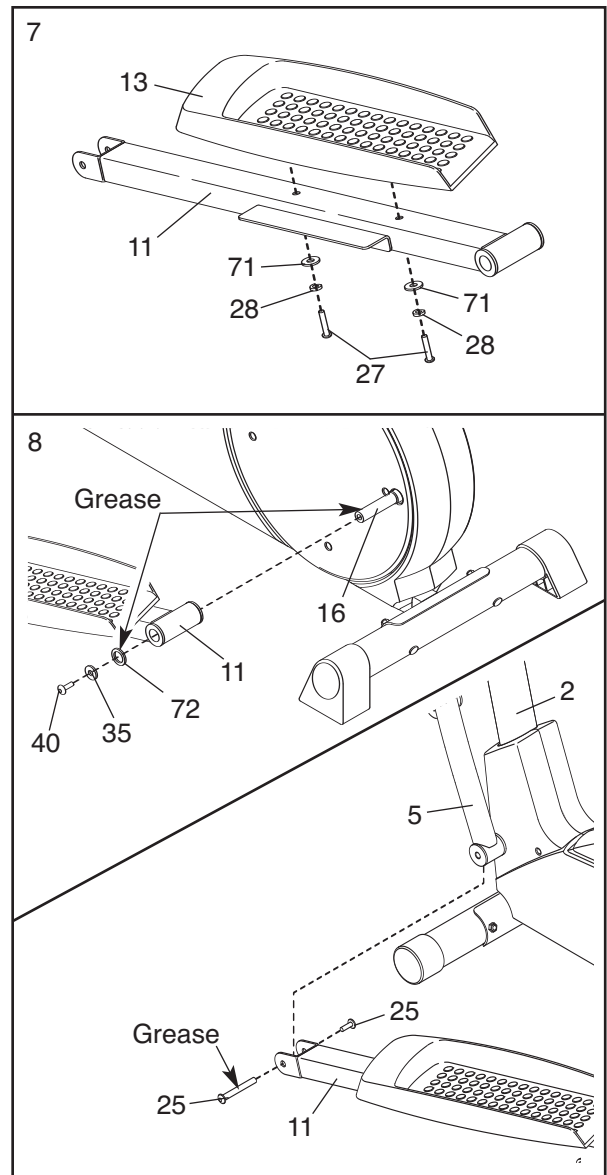

9. **Make sure that all parts of the elliptical crosstrainer are properly tightened.** Note: Some hardware may be left over after assembly is completed. To protect the floor or carpet from damage, place a mat under the elliptical crosstrainer.

HOW TO USE THE ELLIPTICAL CROSSTRAINER

HOW TO ADJUST THE RESISTANCE OF THE PEDALS

As you exercise, you can adjust the resistance of the pedals with the resistance knob on the upright. To increase the resistance, turn the knob clockwise; to decrease the resistance, turn the knob counter-clockwise.

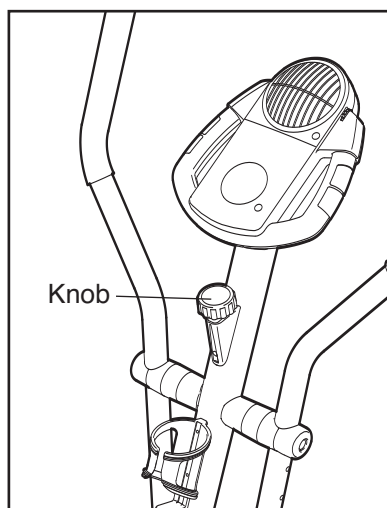

HOW TO EXERCISE ON THE ELLIPTICAL CROSSTRAINER

To mount the elliptical cross-trainer, hold the handles on the console or the handlebars and step onto the pedal that is in the lowest position. Then, step onto the other pedal. Push the pedals until they begin to move with a continuous motion.

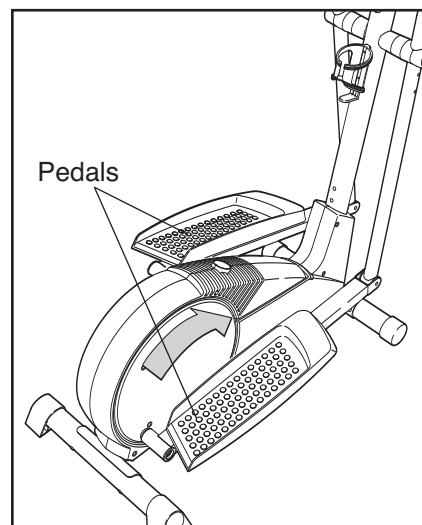

HOW TO USE THE HANDLEBARS

The handlebars are designed to add upper-body exercise to your workouts. As you exercise, push and pull the handlebars to work your arms, shoulders, and back.

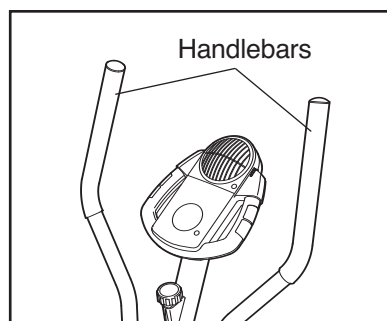

Note: The pedal disks can turn in either direction. It is recommended that you move the pedal disks in the direction shown by the arrow; however, for variety, you may turn the pedal disks in the opposite direction.

To dismount the elliptical cross-trainer, wait until the pedals come to a complete stop. **Note: The elliptical cross-trainer does not have a free wheel; the pedals will continue to move until the flywheel stops.** When the pedals are stationary, step off the highest pedal first. Then, step off the lowest pedal.

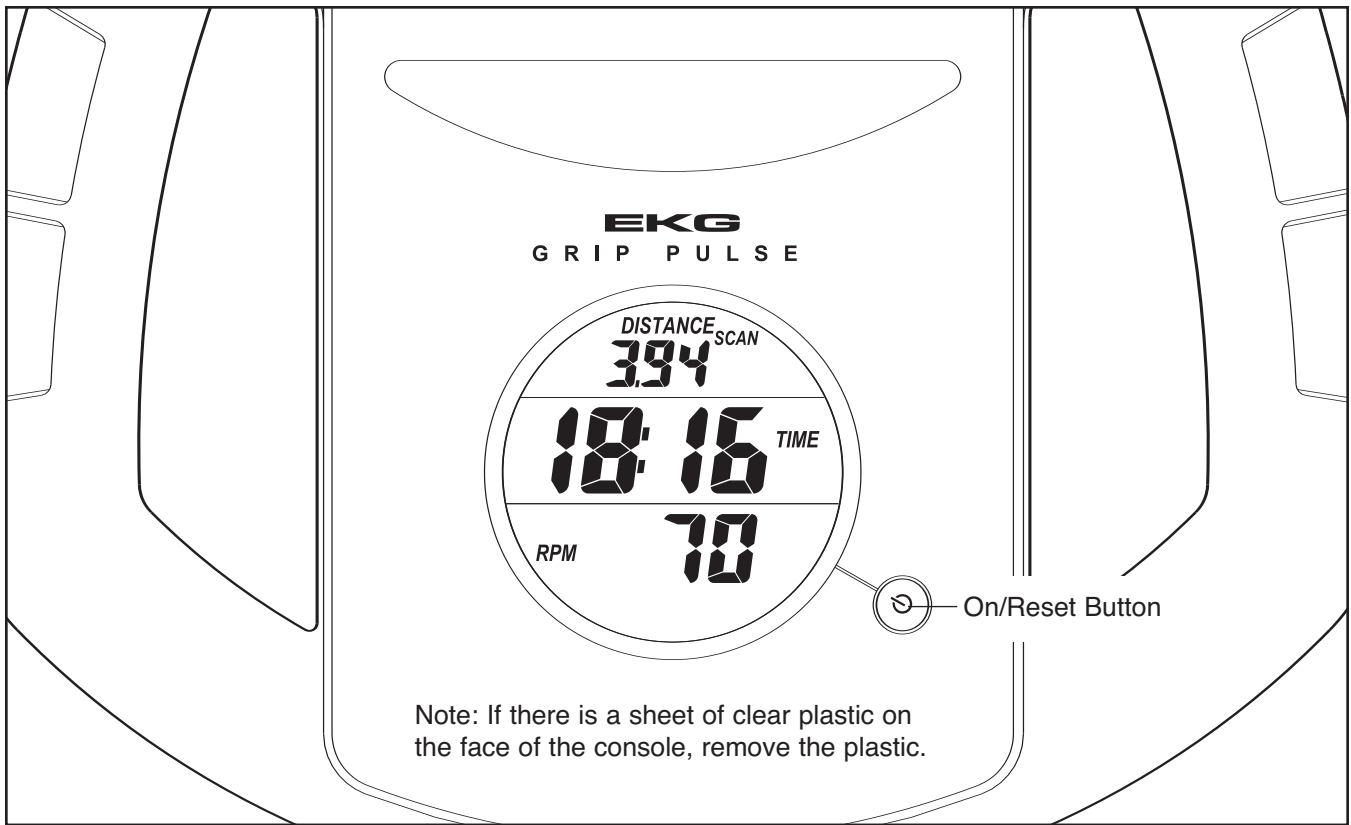

HOW TO USE THE CONSOLE

1 Turn on the console.

Note: The console requires four 1.5V “D” batteries (see assembly step 3 on page 6).

To turn on the console, press the On/Reset button or begin pedaling. (See the drawing above to identify the On/Reset button.)

2 Follow your progress with the display.

The upper section of the display will show the total number of revolutions you have pedaled

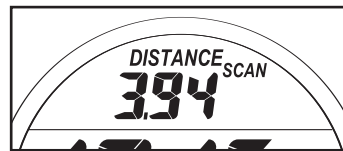

and the numbers of *calories* and *fat calories* you have burned (see FAT BURNING on page 13 for

an explanation of fat calories). The display will change from one number to the next every few seconds. If you use the handgrip pulse sensor, the display will also show your heart rate (see step 3 on page 11).

The center of the display will show the elapsed time you have pedaled.

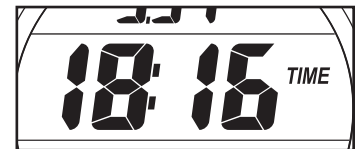

The lower section of the display will show your pedaling pace, in revolutions per minute (RPM).



3 Measure your heart rate if desired.

If there are thin sheets of plastic on the metal contacts on the handgrips, peel off the plastic. To use the handgrip pulse sensor, hold the handgrips with your palms resting against the metal contacts. **Avoid moving your hands.** When your pulse is detected, the heart-shaped indicator in the display will flash each time your heart beats. After a moment, two dashes (– –) will appear and then your heart rate will be shown.

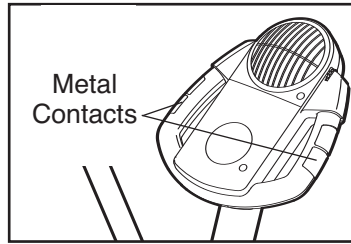

For the most accurate heart rate reading, continue to hold the handgrips for about 30 seconds. Note: When you first hold the handgrips, the display will show your heart rate continuously for 30 seconds. The display will then show your heart rate along with other feedback modes.

4 Turn on the fan if desired.

To turn on the fan at low speed, press the fan button. To turn on the fan at high speed, press the fan button a second time. To turn off the fan, press the fan button a third time. Note: If the fan is turned on but the pedals are not moved for thirty seconds, the fan will automatically turn off to conserve the batteries.

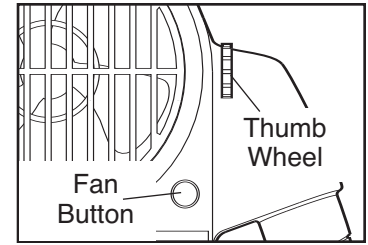

Rotate the thumb wheel on the right side of the console to pivot the fan to the desired angle.

5 When you are finished exercising, the console will automatically turn off.

If the pedals are not moved for a few seconds, the displays will pause and the time will flash in the display. If the pedals are not moved and the console buttons are not pressed for a few minutes, the console will turn off to conserve the batteries.

MAINTENANCE AND TROUBLESHOOTING

Inspect and tighten all parts of the elliptical crosstrainer regularly. Replace any worn parts immediately.

To clean the elliptical crosstrainer, use a damp cloth and a small amount of mild dish soap. **Important: Keep liquids away from the console and keep the console out of direct sunlight. During storage, remove the batteries from the console.**

BATTERY REPLACEMENT

If the console display becomes dim, the batteries should be replaced. See assembly step 3 on page 6 for replacement instructions.

HOW TO ADJUST THE REED SWITCH

If the console does not display correct feedback, the reed switch should be adjusted. To do this, you must remove the Right Pedal Leg (12), the right Pedal Disc (15), and the Side Shields (3, 4). See step 8 on page 8 and remove the Pedal Legs.

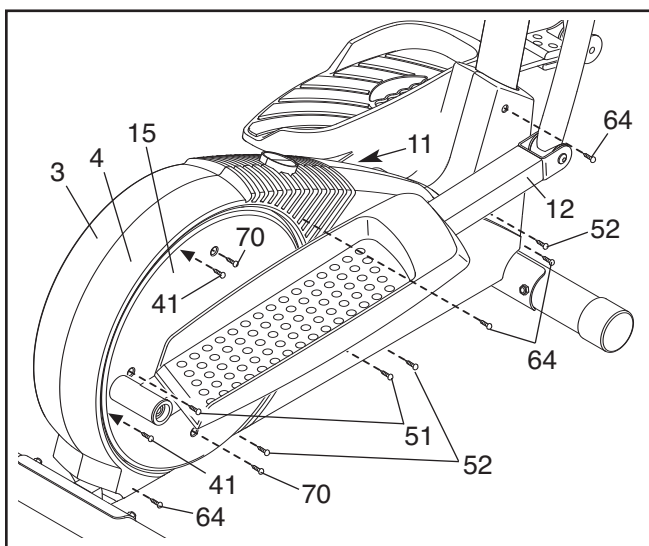

Next, remove the four Screws (51, 70) from the right Pedal Disc (15), and slide the Pedal Disc off. Remove all Screws (52, 64) from the Right Side Shield (4) and the two Bolts (41) from beneath the Pedal Disc, and remove the Right Side Shield (4). Remove all Screws (52) from the Left Side Shield (3), and remove the Left Side Shield.

Next, see the drawing below and locate the Reed Switch (53). Loosen, but do not remove, the indicated M4 x 16mm Self-tapping Screw (52). Slide the Reed Switch slightly toward or away from the Magnet (58) on the flywheel. Retighten the Screw. Turn the left Pedal Disc (15) for a moment. Repeat until the console displays correct feedback. When the Reed Switch is correctly adjusted, reattach the Side Shields (3, 4), the right Pedal Disc (15), and the Pedal Legs (11).

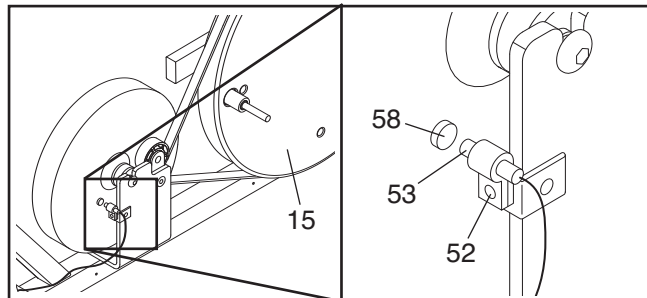

HOW TO ADJUST THE DRIVE BELT

If you can feel the pedals slip while you are pedaling, even when the resistance is adjusted to the highest level, the Drive Belt (19) may need to be adjusted. To adjust the Drive Belt, you must first remove both side shields. See HOW TO ADJUST THE REED SWITCH at the left and remove the side shields.

Next, loosen the M8 x 22mm Flat Head Screw (65) and turn the M10 x 60mm Button Bolt (62) until the Drive Belt (19) is tight. When the Drive Belt is tight, tighten the Flat Head Screw. Reattach the side shields.

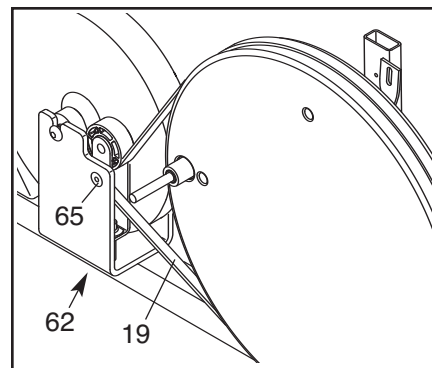

CONDITIONING GUIDELINES



WARNING:

- Before beginning this or any exercise program, consult your physician. This is especially important for persons over the age of 35 or persons with pre-existing health problems.
- The pulse sensor is not a medical device. Various factors, including the user's movement, may affect the accuracy of heart rate readings. The pulse sensor is intended only as an exercise aid in determining heart rate trends in general.

The following guidelines will help you to plan your exercise program. Remember that proper nutrition and adequate rest are essential for successful results.

EXERCISE INTENSITY

Whether your goal is to burn fat or to strengthen your cardiovascular system, the key to achieving the desired results is to exercise with the proper intensity. The proper intensity level can be found by using your heart rate as a guide. The chart below shows recommended heart rates for fat burning, maximum fat burning, and cardiovascular (aerobic) exercise.

165	155	145	140	130	125	115	
145	138	130	125	118	110	103	
125	120	115	110	105	95	90	
20	30	40	50	60	70	80	

To find the proper heart rate for you, first find your age on the bottom line of the chart (ages are rounded off to the nearest ten years). Next, find the three numbers above your age. The three numbers are your “training zone.” The lower two numbers are recommended heart rates for fat burning; the highest number is the recommended heart rate for aerobic exercise.

Fat Burning

To burn fat effectively, you must exercise at a relatively low intensity level for a sustained period of time.

During the first few minutes of exercise, your body uses easily accessible *carbohydrate* calories for energy. Only after the first few minutes of exercise does your body begin to use stored *fat* calories for energy. If your goal is to burn fat, adjust the intensity of your exercise until your heart rate is near the lowest number in your training zone as you exercise.

For maximum fat burning, adjust the intensity of your exercise until your heart rate is near the middle number in your training zone as you exercise.

Aerobic Exercise

If your goal is to strengthen your cardiovascular system, your exercise must be “aerobic.” Aerobic exercise is activity that requires large amounts of oxygen for prolonged periods of time. This increases the demand on the heart to pump blood to the muscles, and on the lungs to oxygenate the blood. For aerobic exercise, adjust the intensity of your exercise until your heart rate is near the highest number in your training zone as you exercise.

WORKOUT GUIDELINES

Each workout should include the following three parts:

A warm-up, consisting of 5 to 10 minutes of stretching and light exercise. A proper warm-up increases your body temperature, heart rate, and circulation in preparation for exercise.

Training zone exercise, consisting of 20 to 30 minutes of exercising with your heart rate in your training zone. (During the first few weeks of your exercise program, do not keep your heart rate in your training zone for longer than 20 minutes.)

A cool-down, with 5 to 10 minutes of stretching. This will increase the flexibility of your muscles and will help to prevent post-exercise problems.

EXERCISE FREQUENCY

To maintain or improve your condition, complete three workouts each week, with at least one day of rest between workouts. After a few months of regular exercise, you may complete up to five workouts each week if desired. The key to success is to make exercise a regular and enjoyable part of your everyday life.

PART LIST—Model No. PFEL29240

R0704A

Key No.	Qty.	Description	Key No.	Qty.	Description
1	1	Frame	39	2	M10 Washer
2	1	Upright	40	2	M10 x 27mm Patch Screw
3	1	Left Side Shield	41	2	M6 x 18mm Bolt
4	1	Right Side Shield	42	1	Resistance Control/Cable
5	2	Handlebar Leg	43	1	Lower Resistance Cable
6	1	Left Handlebar	44	2	Handlebar Endcap
7	2	M10 x 74mm Button Bolt	45	2	M10 Split Washer
8	1	Right Handlebar	46	2	Handlebar Cap
9	1	Rear Stabilizer	47	2	Handlebar Spacer
10	1	Front Stabilizer	48	2	Frame Spacer
11	1	Left Pedal Leg	49	6	Small Handlebar Bushing
12	1	Right Pedal Leg	50	4	M8 x 45mm Button Bolt
13	1	Left Pedal	51	4	M6 x 25mm Screw
14	1	Right Pedal	52	10	M4 x 16mm Self-tapping Screw
15	2	Pedal Disc	53	1	Reed Switch/Wire
16	2	Disc Crossbar	54	1	Cable Clamp
17	1	Flywheel	55	2	Handlebar Washer
18	1	Side Shield Bracket	56	2	M8 x 25mm Patch Screw
19	1	Drive Belt	57	1	Flywheel Axle
20	2	Rear Endcap	58	1	Magnet
21	2	Front Endcap	59	4	Console Screw
22	1	Belt Idler	60	4	Large Handlebar Leg Bushing
23	1	Console	61	2	5/16" x 25.4mm Hex Bolt
24	2	Handgrip	62	1	M10 x 60mm Button Bolt
25	2	M10 Bolt Set	63	2	M4 x 22mm Screw
26	1	Pivot Axle	64	4	M4 x 25mm Screw
27	4	M8 x 52mm Button Screw	65	1	M8 x 22mm Flat Head Screw
28	4	M8 Split Washer	66	2	M6 Nylon Locknut
29	1	Water Bottle Holder	67	2	M5 x 14mm Self-tapping Screw
30	2	Large Snap Ring	68	1	Extension Wire
31	2	Large Bearing	69	2	Wave Washer
32	1	Pedal Axle	70	4	M6 x 28mm Screw
33	7	M10 Nylon Locknut	71	4	M8 Washer
34	4	M10 x 75mm Carriage Bolt	72	2	Large Wave Washer
35	2	Pedal Leg Washer	#	1	Allen Wrench
36	2	M3 x 12mm Screw	#	1	Grease
37	4	Pedal Arm Bushing	#	1	User's Manual
38	5	M8 Nylon Locknut			

Note: # indicates a non-illustrated part. Specifications are subject to change without notice.

EXPLODED DRAWING—Model No. PFEL29240

R0704A

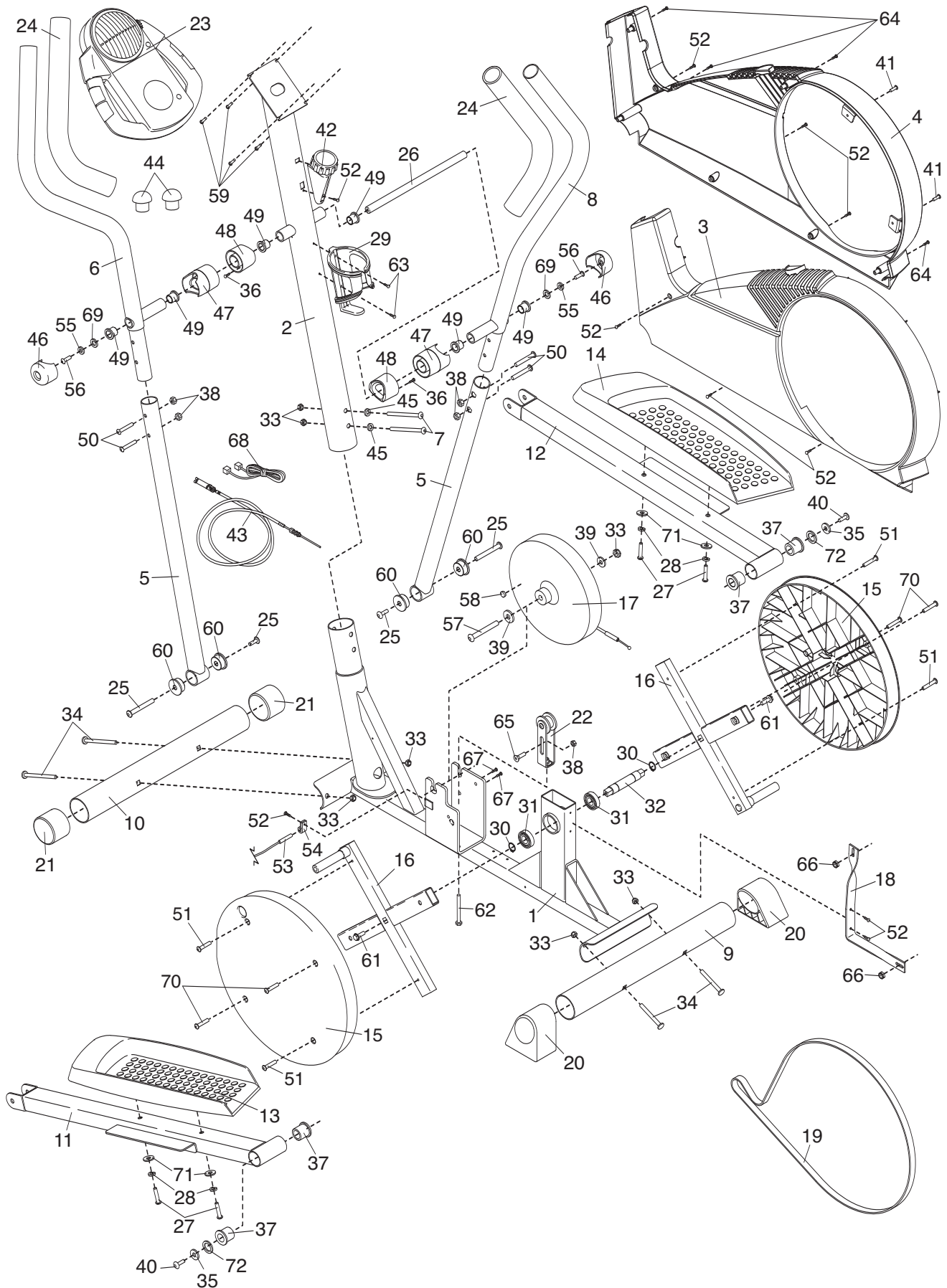

HOW TO ORDER REPLACEMENT PARTS

To order replacement parts, simply call our Customer Service Department toll-free at 1-888-533-1333, Monday through Friday, 6 a.m. until 6 p.m. Mountain Time (excluding holidays). To help us assist you, please be prepared to give the following information when calling:

- The MODEL NUMBER of the product (PFEL29240)
- The NAME of the product (PROFORM 675 CARDIO CROSSTRAINER)
- The SERIAL NUMBER of the product (see the front cover of this manual)
- The KEY NUMBER and DESCRIPTION of the part(s) (see page 14)

LIMITED WARRANTY

ICON Health & Fitness, Inc. (ICON), warrants this product to be free from defects in workmanship and material, under normal use and service conditions, for a period of ninety (90) days from the date of purchase. This warranty extends only to the original purchaser. ICON's obligation under this warranty is limited to replacing or repairing, at ICON's option, the product through one of its authorized service centers. All repairs for which warranty claims are made must be pre-authorized by ICON. This warranty does not extend to any product or damage to a product caused by or attributable to freight damage, abuse, misuse, improper or abnormal usage or repairs not provided by an ICON authorized service center; products used for commercial or rental purposes; or products used as store display models. No other warranty beyond that specifically set forth above is authorized by ICON.

ICON is not responsible or liable for indirect, special or consequential damages arising out of or in connection with the use or performance of the product or damages with respect to any economic loss, loss of property, loss of revenues or profits, loss of enjoyment or use, costs of removal or installation or other consequential damages of whatsoever nature. Some states do not allow the exclusion or limitation of incidental or consequential damages. Accordingly, the above limitation may not apply to you.

The warranty extended hereunder is in lieu of any and all other warranties and any implied warranties of merchantability or fitness for a particular purpose is limited in its scope and duration to the terms set forth herein. Some states do not allow limitations on how long an implied warranty lasts. Accordingly, the above limitation may not apply to you.

This warranty gives you specific legal rights. You may also have other rights which vary from state to state.

ICON HEALTH & FITNESS, INC., 1500 S. 1000 W., LOGAN, UT 84321-9813